

PROGRAMMER INTERFACE

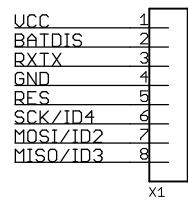

TOUCH-SENSOR

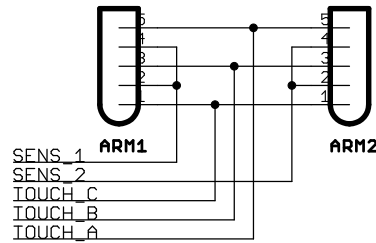

BOB-ID

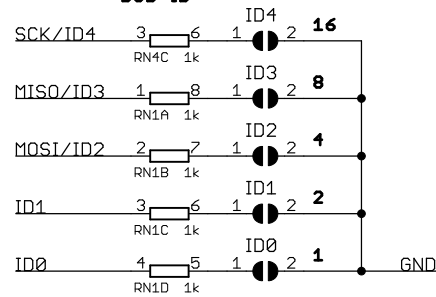

IR-SENSOR

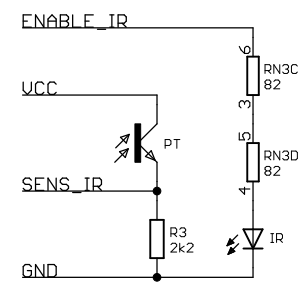

WHITE-LEDS

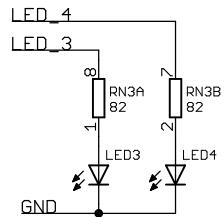

TOUCH-AMPLIFIER

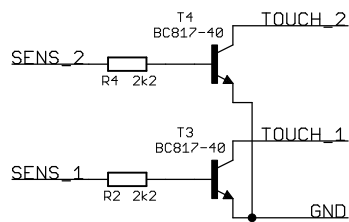

MICROCONTROLLER

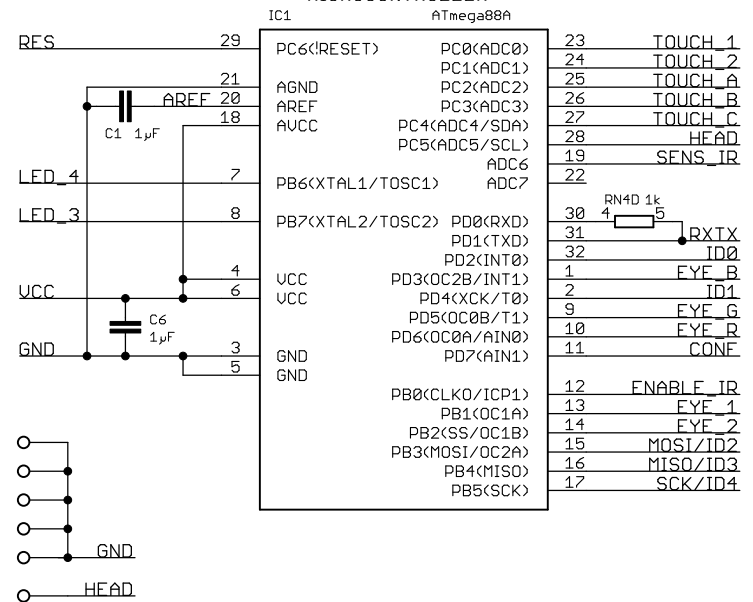

RGB-LEDS

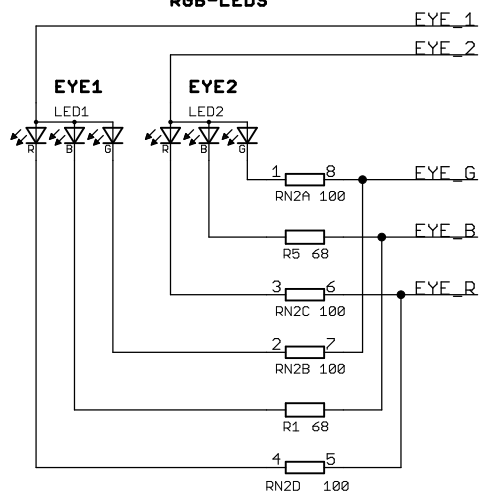

BATTERY SUPPLY

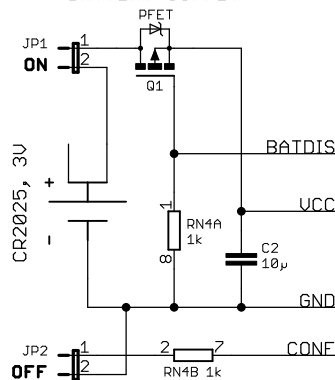

| | |
|---|---|
| Project: BOB3-Bloom | REV: V1.5B |
| BOB3-THT Robot Unit | |
| MCU, Sensors, LEDs and Power | |
| Info: http://www.bob3.org | HTTPS://Q.NICA1.EU/ |
| Engineer: Nils Springob | 5KEI3 |
| Date: 15.05.26 13:55 | Sheet: 1/1 |